



# Sensor Development Kit (SDK)

Instrument User Manual V1.0



The standard warranty of your Sensor Development Kit is one year.

## Contents

---

<b>Contents</b>	<b>3</b>
<b>Statements</b>	<b>5</b>
Validity of this Manual .....	5
Responsibility for Correct Use .....	5
Warnings .....	5
Quality Assurance.....	5
Disposal .....	5
Legal Notice .....	6
Warranty .....	6
Contact details.....	7
<b>Introduction to the Sensor Development Kit (SDK)</b>	<b>8</b>
Technical Specification .....	8
<b>System Description</b>	<b>9</b>
Outputs and Communications .....	9
<b>RS485 Modbus Interface</b>	<b>9</b>
Location Requirements .....	10
Power Requirements.....	10
Cable Requirements .....	10
Dimensions for Installation .....	10
Connections.....	11
<b>Installing the configuration software</b>	<b>12</b>
Configuring the Integration Board .....	12
<b>Spare Parts</b>	<b>17</b>
<b>Manual Log</b>	<b>17</b>

## Symbols

---

**WARNING!**

USED TO INDICATE DANGER WARNINGS WHERE THERE IS A RISK OF INJURY OR DEATH.

**WARNING! - DANGER OF ELECTRIC SHOCK**

USED TO INDICATE DANGER WARNINGS WHERE THERE IS A RISK OF INJURY OR DEATH FROM ELECTRIC SHOCK.

**CAUTION**

USED TO INDICATE A CAUTION WHERE THERE IS A RISK OF DAMAGE TO EQUIPMENT.

**PROHIBITED ACTION**

USED TO INDICATE ACTIONS THAT ARE NOT PERMITTED; E.G. 'YOU MUST NEVER'.

**INFORMATION**

IMPORTANT INFORMATION OR USEFUL HINTS ABOUT USAGE.

## Recycling and Disposal

---

**RECYCLING**

RECYCLE ALL PACKAGING.

**WEEE REGULATIONS**

ENSURE THAT WASTE ELECTRICAL EQUIPMENT IS DISPOSED OF CORRECTLY.

## Statements

---

### Validity of this Manual

This User Manual gives information and procedures for the firmware version shown on the back page of this manual.

If you have different versions of firmware, please obtain the correct User Manual.

### Responsibility for Correct Use

Ion Science Ltd accepts no responsibility for incorrect adjustments, configurations or installations that cause harm or damage to persons or property.

Use the equipment in accordance with this manual, and in compliance with local safety standards.

Reduced performance of gas detection might not be obvious, so equipment must be inspected and maintained regularly. Ion Science recommends:

- you use a schedule of regular checks to ensure it performs within calibration limits, and that
- you keep a record of calibration check data.

ION Science Ltd SDK boards are not authorised for use in safety-critical applications where a failure of the ION Science Ltd product would reasonably be expected to cause severe personal injury or death. Safety-critical applications include, without limitation, life support devices and systems, equipment or systems for operation in Hazardous Areas or Zones. ION Science Ltd products are neither designed nor intended for use in military or aerospace applications or environments, nor for automotive applications or the automotive environment. The Customer acknowledges and agrees that any such use of ION Science Ltd products is solely at the Customer's risk, and that the Customer is solely responsible for compliance with all legal and regulatory requirements in connection with such use.

### Warnings

1. Read and understand this Manual fully before you install or operate the SDK.
2. For safety, the SDK must only be installed by qualified personnel.
3. All electrical work must be only carried out by competent persons.
4. Substitution of components can result in unsafe conditions and will invalidate the warranty.
5. It is the responsibility of the user to ensure that PCB's are adequately protected from sources of EMI.
6. It is the responsibility of the user to ensure that PCB's are adequately protected from unsafe voltage conditions that could be transmitted into any connected equipment or systems.
7. It is the users responsibility to assess risk when working with toxic and flammable compounds. Relevant protective equipment must be used.

### Quality Assurance

The SDK is manufactured using business systems complying to the ISO 9001 standard. That ensures that the equipment is:

- designed and assembled reproducibly, from traceable components,
- calibrated to the stated standards before it leaves our factory.

### Disposal

Dispose of the SDK and its components in accordance with all local and national safety and environmental requirements. This includes the European WEEE (Waste Electrical and Electronic

Equipment) directive. Ion Science Ltd offers a take-back service. Please contact us for more information.

### **Legal Notice**

Whilst every attempt is made to ensure the accuracy of the information contained in this manual, Ion Science accepts no liability for errors or omissions, or any consequences deriving from the use of information contained herein. It is provided "as is" and without any representation, term, condition or warranty of any kind, either expressed or implied. To the extent permitted by law, Ion Science shall not be liable to any person or entity for any loss or damage which may arise from the use of this manual. We reserve the right at any time and without any notice to remove, amend or vary any of the content which appears herein.

### **Warranty**

ION Science Ltd warrants that its products will conform to the Specifications.

This warranty lasts for one (1) year from the date of the sale.

ION Science Ltd shall not be liable for any defects that are caused by neglect, misuse or mistreatment by the Customer, including improper installation or testing, or for any products that have been altered or modified in any way by the Customer. Moreover, ION Science Ltd shall not be liable for any defects that result from the Customer's design, specifications, installations or instructions or incorrect interfacing for such products. Testing and other quality control techniques are used to the extent ION Science Ltd deems necessary.

If any ION Science Ltd product fails to conform to the warranty set forth above, ION Science Ltd's sole liability shall be to replace such products. ION Science Ltd's liability shall be limited to products that are determined by ION Science Ltd not to conform to such warranty. If ION Science Ltd elects to replace such products, ION Science Ltd shall be given a reasonable time to provide replacements. Replaced products shall be warranted for a new full warranty period. ION Science Ltd shall not be liable for any freight costs incurred.

In no event shall ION Science Ltd be liable to the Customer or any third parties for any special, collateral, indirect, punitive, incidental, consequential or exemplary damages in connection with or arising out of the products provided hereunder, regardless of whether ION Science Ltd has been advised of the possibility of such damages. This indemnity will survive the termination of the warranty period.

**Contact details****Head Office (UK)**

Ion Science Ltd  
The Hive, Butts Lane,  
Fowlmere  
Cambridge  
SG8 7SL  
UK

**Tel:** +44 (0)1763 208503

**Fax:** +44 (0) 1763 208814

**Email:** [info@ionscience.com](mailto:info@ionscience.com)

**Web:** [www.ionscience.com](http://www.ionscience.com)

**US Corporate HQ**

Ion Science Inc  
4153 Bluebonnet Drive, Stafford  
Texas  
77477  
USA

**Tel:** +1 877 8647710

**Email :** [info@ionscienceusa.com](mailto:info@ionscienceusa.com)

**Web:** [www.ionscience.com](http://www.ionscience.com)

**German Office**

Ion Science Messtechnik  
GMBH  
Laubach 30  
Metmann-Neandertal  
40822  
GERMANY

**Tel:** +49 2104 14480

**Fax:** +49 2104 144825

**Email:** [info@ism-d.de](mailto:info@ism-d.de)

**Web:** [www.ism-d.de](http://www.ism-d.de)

**Italian Office**

Ion Science Italia  
Via Emilia 51/c  
40011 Anzola Emilia  
Bologna  
ITALY

**Tel:** +39 051 0561850

**Fax:** +39 051 0561851

**Email:** [info@ionscience.it](mailto:info@ionscience.it)

**Web:** [www.ionscience.it](http://www.ionscience.it)

**China Office**

Ion Science China Ltd  
1101, Building B  
Far East International Plaza  
No. 317 Xiaxia Road  
Shanghai  
CHINA

**Tel:** +86 21 52545988

**Fax:** +86 21 52545986

**Email:** [info@ionscience.cn](mailto:info@ionscience.cn)

**Web:** [www.ionscience.cn](http://www.ionscience.cn)

## Introduction to the Sensor Development Kit (SDK)

---

The ION Science SDK consists of two PCBs designed to enable users to test and integrate MiniPID VOC sensors into their applications.

The sensor board holds an ION Science MiniPID 2 sensor and is fitted with a gas hood to allow easy introduction of gas to the sensor.

The integration board supplies power to the sensor board and can be configured to provide an analogue input, analogue output as well as a digital and serial output (Modbus). The integration board stores calibration values for the sensor and will also log and store data from all inputs.

### Technical Specification

<b>Name</b>	Sensor board
<b>Dimensions</b>	50mm x 62mm
<b>Weight</b>	40g (72g when fitted with hood & PID)
<b>Nominal Voltage</b>	5 VDC $\pm$ 500mV
<b>Supply Cables</b>	0.5 to 1.5mm <sup>2</sup>
<b>Flow Rate (max)</b>	300 ml/min
<b>Pressure (max)</b>	Ambient air pressure + 50 mbar (please refer to MiniPID2 manual)
<b>Operating Humidity:</b>	0 – 99 RH% (non-condensing)
<b>Storage Temperature</b>	-20 °C to +60 °C

<b>Name</b>	Integration board
<b>Dimensions</b>	99mm x 82mm
<b>Weight</b>	70g
<b>Nominal Voltage</b>	12V to 30Vdc $\pm$ 500mV
<b>Typical Power</b>	< 200mA when connected to a PID via the sensor board
<b>Supply Cables</b>	0.5 to 1.5mm <sup>2</sup>
<b>Maximum Contact Load</b>	100 Vac / 2A
<b>Operating Humidity:</b>	0 – 99 RH% (non-condensing)
<b>Storage Temperature</b>	-20 °C to +60 °C

<b>Name</b>	Gas delivery hood
<b>Dimensions</b>	Total height including PCB 40mm
<b>Pipe Connection</b>	1/16" OD barb push fit 1/16" ID/1/8" OD Viton pipe recommended
<b>Seal material</b>	Viton
<b>Maximum gas pressure</b>	<300 mBar

All specifications quoted are at calibration point and under the same ambient conditions. Specifications are based on isobutylene calibration at 20°C and 1000 mBar.



**System Description**

---

**Outputs and Communications**

The integration board has:

- 1 x 4-20mA current loop output.
- 1 x 4-20mA current loop input.
- 1 x RS485 Modbus® channel.
- 1 x programmable relay.

The 4-20mA output is an analogue representation of the calibrated sensor value.

You can program a normally open relay to operate at a chosen concentration of gas. This is setup in the companion software, available from [www.ionscience.com](http://www.ionscience.com). The relay can switch a maximum of 250VAC / 2A maximum load.

The integration board can be configured as a Modbus® RS485 slave. For further details of the available data registers please see below.

**RS485 Modbus Interface**

---

The SDK Modbus interface uses Modbus RTU

- 9600 or 19200 baud, 8 data bits, no parity, 1 stop bit.

Name	Address (hex)	Length (decimal)(bytes)	Notes
PIDGOOD	1200	2	Returns 1 if PID Power OK, 0 if not
POWERGOOD	1202	2	Returns 1 if Power OK, 0 if not
ADCMV	1260	24	Returns array of 6 x 32 bits values. [0] = RTD - raw ADC input in $\mu$ V [1] = 10V - raw ADC input in $\mu$ V [2] = PID - raw ADC input in $\mu$ V [3] = LIGHT - raw ADC input in $\mu$ V [4] = TEMPERATURE - raw ADC input in $\mu$ V [5] = 4-20 - raw ADC input in ADC units
SIGNAL	12C0	24	Returns array of 6 x float values: [0] = RTD - Temperature in degC or degF [1] = 10V - Scaled Input [2] = PID - Signal in ppm [3] = LIGHT - 1.0 if lamp on, 0.0 if lamp off [4] = TEMPERATURE - Internal Temperature in degC [5] = 4-20 - Scaled Input  The "Scaled Inputs" are scaled according to the configured user calibration.

**Location Requirements**

It is recommended that the integration board is housed in a metallic enclosure to protect against EMI from outside influences.

**Power Requirements**

The integration board must be powered from a stable 12-30VDC supply.

**Cable Requirements**

We recommend you use screened cables to protect against EMI.

The manufacture and build of the cable glands is the responsibility of the installer/system designer.

**Dimensions for Installation**

**Integration Board**

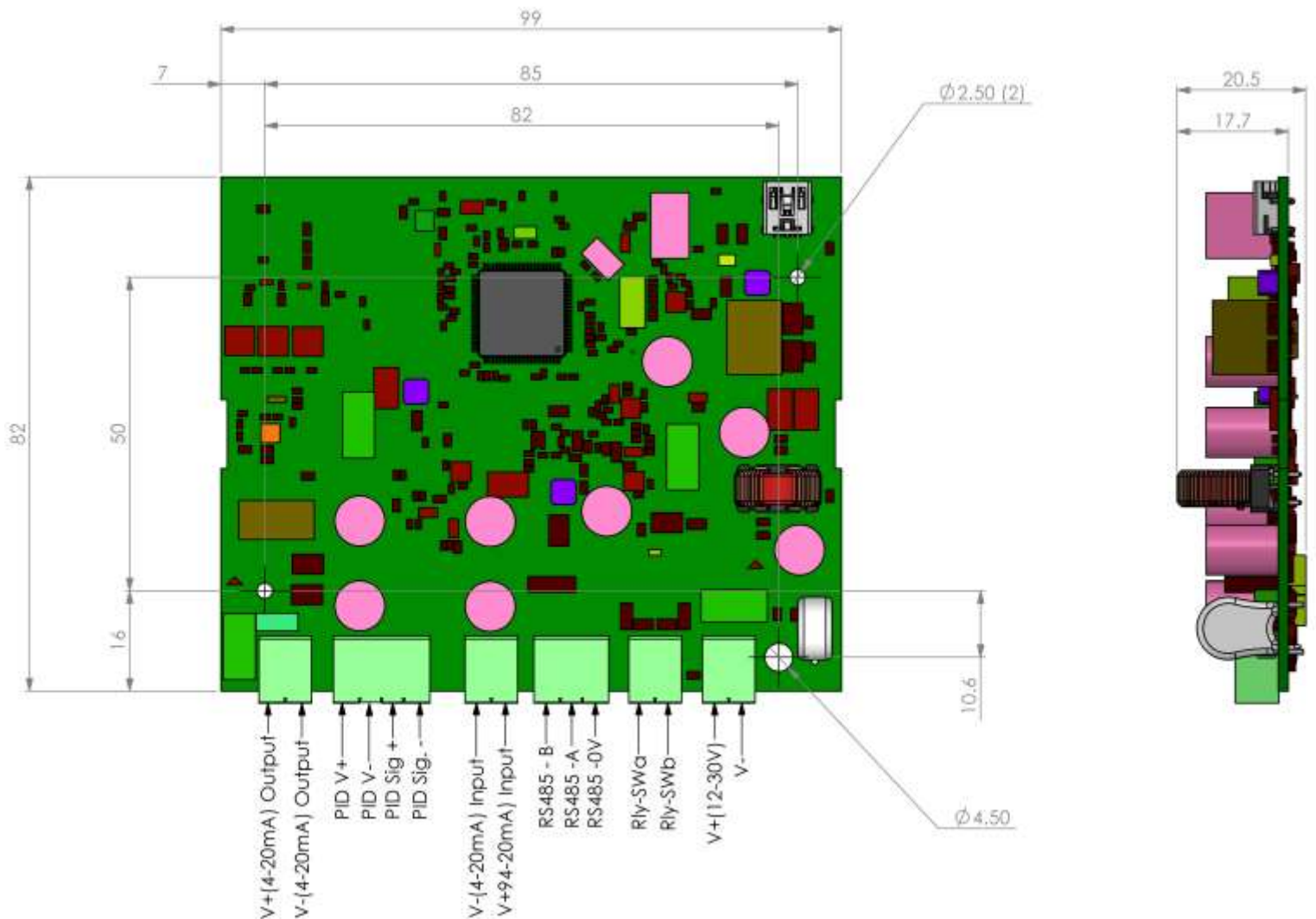

**Sensor Board**

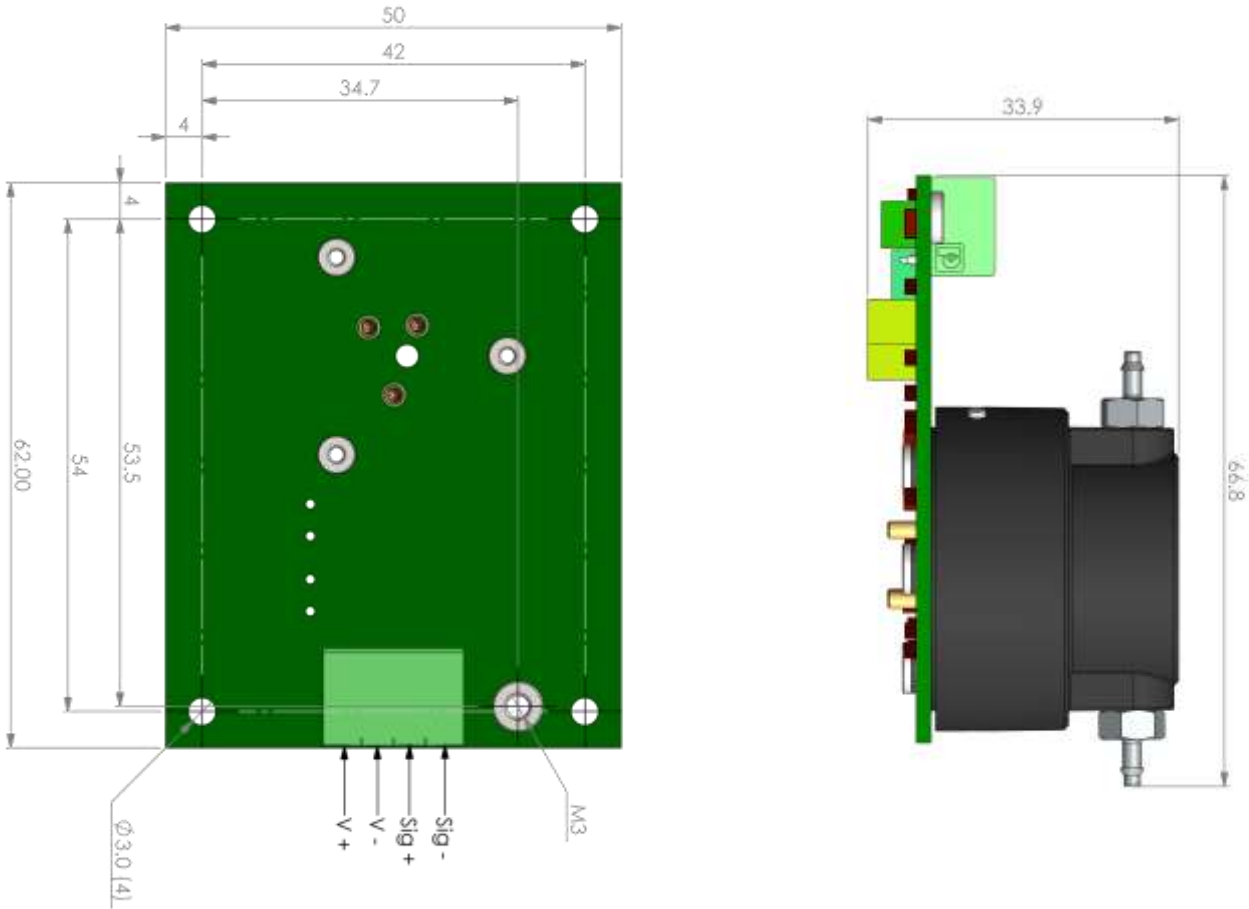

**Note: maximum conductor size is 1.5mm<sup>2</sup>**

**Connections**

The sensor board is connected to the integration board in the manner shown below. Cabling between the boards should be shielded.

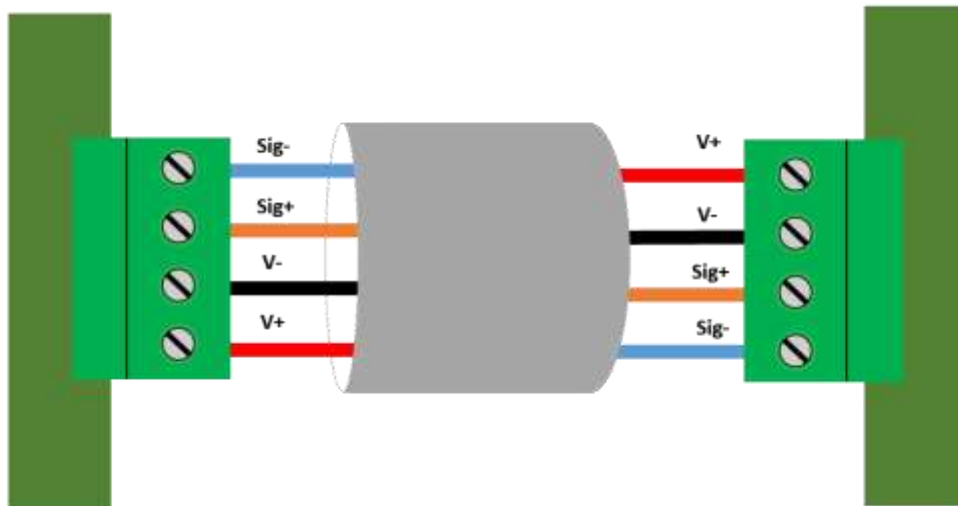

## Installing the configuration software

---

The integration board is configured using a Windows® based software tool. The software is available for download from [www.ionscience.com](http://www.ionscience.com). The software is compatible with Windows® 7,8 and 10.

1. Download the software.
2. Open the .zip file that contains the software.
3. Double click the setup.exe file.
4. The setup wizard will begin.
5. On the setup wizard dialogue, click “Next >”.
6. Use the “Browse” button to select a location for the wizard to install the integration board software or accept the default “C:\IonScience” folder and click “Next >”.
7. Choose a folder for the program shortcut and click “Next >”.
8. Select or deselect the tick box to create a desktop icon and click “Next >”.
9. Check the summary screen and if you are happy with the proposed structure, click “Install”.
10. Your software is now installed.

## Configuring the Integration Board

### Connection

1. Before connecting the integration board to your PC, please ensure you have connected the sensor PCB, fitted with a MiniPID 2 sensor.
2. Power up the integration board using a suitable DC power supply (12-30Vdc).
3. Connect the integration board to your computer with a USB A to USB mini B cable.
4. Open the configuration software and at the top of the page, select USB and click “Connect”.

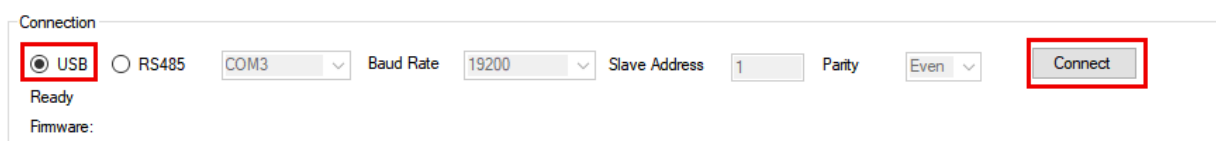

5. When the integration board has connected successfully, you will see the Unique ID and firmware version of the board will appear. It is also possible to connect to the board via an RS485 adaptor.

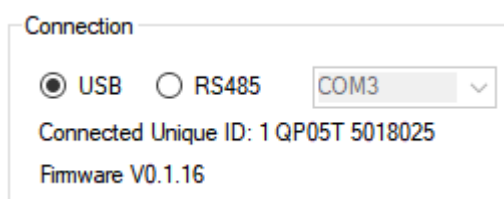

## RTC

1. Set the realtime clock on the integration board (this is important for datalogging accurately). To do this, in the RTC section, click “Set to PC clock”. you will see a confirmation and the clock on the board will be synchronised with the clock on your PC.

## Modbus

1. In the Modbus section of the software, you are able to configure the integration board as a Modbus<sup>®</sup> slave device. This allows you to collect data from the boards remotely.
2. Set the slave device address to a value between 1 – 254. Each integration board on a Modbus<sup>®</sup> network must have a unique slave address.
3. Set the baud rate and parity to suit your network. Please note that all devices on the same Modbus<sup>®</sup> network must have the same baud and parity settings.
4. When the Modbus<sup>®</sup> settings are correct click “Set” to save the settings to the integration board.

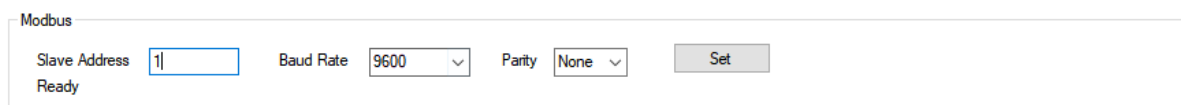

The screenshot shows a software interface for configuring Modbus settings. It includes a title bar labeled 'Modbus'. Below the title bar, there are three input fields: 'Slave Address' with the value '1', 'Baud Rate' with the value '9600', and 'Parity' with the value 'None'. Each field has a small downward arrow indicating it is a dropdown menu. To the left of the 'Slave Address' field, the text 'Ready' is visible. To the right of the 'Parity' field, there is a grey 'Set' button.

## PID Setup and Calibration

To calibrate the PID sensor you will require the following:-

- 1 x cylinder of zero air fitted with a 300ml/min fixed flow regulator.
- 1 x cylinder of Isobutylene fitted with a 300ml/min fixed flow regulator for the first calibration span.
- 1 x cylinder of Isobutylene fitted with a 300ml/min fixed flow regulator for the 2<sup>nd</sup> calibration span (if doing 2 span calibration).
- Tubes to connect regulators to gas hood. The barb on the gas hood is suitable for 1/16” inner diameter tubing.
- A connected sensor board fitted with a PPM or PPB MiniPID2 sensor.

## Procedure

In the PID section, the integration board can be setup to read data from a MiniPID 2 sensor. The integration board can also be calibrated. This calibration is stored on the integration board meaning the integration board will output a calibrated PPM (parts per million) value.

1. To begin configuring the sensor, first select the correct type of sensor you are using from the dropdown. Choose either PPM or PPB.
2. Now select the correct measurement range for your application either 1 – 100ppm or 1-1000ppm. **This is very important as this determines the scale of the 4-20mA output on i.e. on 100ppm range 0ppm = 4mA 100ppm = 20mA on 1000ppm range 0ppm = 4mA 1000ppm = 20mA.**
3. Enable the sensor by clicking the checkbox.
4. If the sensor is operational, the coloured indicator will be green. If there is an issue with the sensor, the fault will be displayed within the coloured indicator. You will also notice a blue LED will switch on under the PID sensor. This blue LED is to aid the lamp in striking.
5. Connect the zero air to the gas hood and switch on the air supply. Leave the zero air connected to the PID for 2 minutes.
6. After 2 minutes have elapsed, press the “Set Zero Value” button. This will store the zero value in memory.
7. Enter the gas concentration for the first calibration span.

The screenshot shows the PID calibration interface. The 'Enable' checkbox is checked. The sensor type is set to 'PPM'. The calibration gas is 'ISOBUTYLENE'. The range is '0.01-100 ppm'. A green indicator displays '0.01 ppm'. The 'Set Zero Value' button is visible, and the 'Stored Zero Value' is 60.545 mV. The 'Set Span Value' button is highlighted with a red box, and the 'Concentration' field is set to '100 ppm', also highlighted with a red box. The 'Stored Span Value' is 263.048 mV. The 'Use Span 2' checkbox is unchecked.

8. Now, connect your span 1 isobutylene cylinder to the gas hood and switch on the gas supply. Leave the gas connected for 2 minutes.
9. After 2 minutes have elapsed, press the “Set Span Value” button. This will store the span 1 value in memory. If you are not using a second span calibration, then calibration is complete.
10. If applicable, tick the “Use Span 2” box.
11. Enter the gas concentration for the second calibration span.

The screenshot shows the PID calibration interface after the second span is configured. The 'Enable' checkbox is checked. The sensor type is 'PPM'. The calibration gas is 'ISOBUTYLENE'. The range is '0.01-100 ppm'. An orange indicator displays '0.02 ppm'. The 'Set Zero Value' button is visible, and the 'Stored Zero Value' is 60.545 mV. The 'Set Span Value' button is visible, and the 'Stored Span Value' is 263.048 mV. The 'Use Span 2' checkbox is checked and highlighted with a red box. The 'Set Span 2 Value' button is visible, and the 'Concentration' field is set to '1000 ppm', also highlighted with a red box. The 'Stored Span Value' is empty.

12. Now, connect your span 2 isobutylene cylinder to the gas hood and switch on the gas supply. Leave the gas connected for 2 minutes.

- After 2 minutes have elapsed, press the “Set Span Value” button. This will store the span 2 value in memory. Calibration is now complete.

## I/O Config

The integration board has a single 4-20mA input channel that can be used to log data from other sensors and instrumentation. This data can be logged along with data from the PID sensor.

**I/O Config**

	Log Input?	Type	UoM		Scale	Decimals
4-20mA Input	<input checked="" type="checkbox"/>	<input type="text" value="Cold Room Temperature"/>	<input type="text" value="oC"/>	Min	<input type="text" value="10.00"/> Max <input type="text" value="50.00"/>	<input type="text" value="2"/>
<input type="button" value="Write Config"/>						
Relay Output		Threshold: <input type="text" value="100.00"/> ppm	Hysteresis: <input type="text" value="10.00"/> ppm	Configuration Written		

---

**I/O Measure**

Enable

4-20mA Input	Cold Room Temperature	<input type="text" value="1.48"/>	oC	PID Input	marker	<input type="text" value="0.22"/>	ppm
--------------	-----------------------	-----------------------------------	----	-----------	--------	-----------------------------------	-----

- In the I/O config section, select “Log Input?”.
- Move to the “Type” text field and enter the name of the device you are logging.
- In the “UoM” text field, enter the unit of measure for the device you are logging.
- In the scale text fields, enter the minimum and maximum value of the device you are logging. The Integration board will rescale the 4-20mA input based on this.
- In the “Decimals” field you need to specify the number of decimal places you wish to record.
- If you wish to use the onboard relay, it is enabled by specifying the PPM level at which you wish to the relay to activate. You also need to specify the level of hysteresis required.  
**Please note the relay will not operate until the board is actively datalogging.**
- Once this is complete, click the “Write config” button. This will save all of these settings to the Integration board.
- To view live values from the PID and the 4-20mA input, navigate to the “I/O Measure” section and click “Enable”. You will now see live values being displayed.

## Logging

The integration board has 256KB of memory. The first 768 Bytes are used to store calibration and configuration data leaving roughly 255KB for datalogs. The integration board memory runs on a circular buffer, meaning that when the memory becomes full, the oldest data will be overwritten first. Duration of data storage is dependent on the configured interval for datalogging. Each datalog entry is around 41 bytes.

- Configure the logging interval by first selecting the units either minutes or seconds.

2. Now enter the number of minutes or seconds you require the logging interval to be.
3. Click “Write Settings” to save the datalogging settings to the integration board.
4. To start datalogging click the “Start Logging” button.
5. To stop datalogging click the “Stop Logging” button. If you wish to view the datalogs you can either view them in the software or you can export them to a CSV file.
6. To view datalogs within the software, click the “Start Download” button.
7. To export a CSV file with all logged data, click “Export Data”. A save file dialogue will open so you can choose the name and save location of the downloaded CSV file.



The screenshot shows a software interface for logging data. At the top, there is a 'Logging' section with a 'Logging Interval' set to '1' seconds, a 'Write Settings' button, and buttons for 'Stop Logging', 'Start Download', and 'Clear Data'. Below this, a 'Ready' status is shown next to a green progress bar labeled 'Logging: 575 readings' and an 'Export Data' button. The main part of the interface is a table with the following data:

Date/Time	PID (ppm)	Cold Room Temperature (°C)	Faults
02/07/2018 13:36:05	81.44	1.51	
02/07/2018 13:36:06	83.81	1.51	
02/07/2018 13:36:07	84.01	1.48	
02/07/2018 13:36:08	83.94	1.51	
02/07/2018 13:36:09	83.87	1.51	
02/07/2018 13:36:10	83.82	1.51	



**Spare Parts**

---

Item No	Part
1	PID gas hood
2	PPM MiniPID2
3	PPB MiniPID2
4	HPPM Electrode Stack (Blue)
5	PPB Electrode Stack (White)
6	Mini PID Electrode Stack Removal Tool
7	MiniPID Lamp Spring
8	PID Lamp Cleaning Kit

**Manual Log**

---

Manual Version	Amendment	Issue Date	Instrument Firmware	PC Software
1.0	First Issue	27/11/18	V0.1.22	